

1. On a hot summer day, the air temperature is  $37^{\circ}\text{C}$ . Express this temperature in kelvin and  $^{\circ}\text{F}$ .

- a)  $69^{\circ}\text{F}$ , 310 K
- b)  $98.6^{\circ}\text{F}$ , 310 K
- c)  $66.6^{\circ}\text{F}$ , 310 K
- d)  $98.6^{\circ}\text{F}$ , 300 K
- e)  $69^{\circ}\text{F}$ , 300 K
- f)  $70^{\circ}\text{F}$ , 350 K

2. How much heat is lost by 250 ml of water as it cools from  $50^{\circ}\text{C}$  to  $25^{\circ}\text{C}$ ? Take its density be  $1\text{ g/cm}^3$  and its specific heat be  $1\text{ cal}/(\text{g}\cdot^{\circ}\text{C})$ .

- a) 6250 cal
- b) 10 cal
- c) 0.1 cal
- d) 625 cal
- e) 62.5 kcal
- f) 100 kcal

3. A mass of 2 kg is pulled by a constant force of 10 N, causing it to move on a horizontal frictioned floor with a constant acceleration of  $4\text{ m/s}^2$  for a distance of 9 m. Determine the work done by the frictional force.

- a) 90 J
- b) 72 J
- c) 36 J
- d) 18 J
- e) 20 J
- f) 9 J

4. Surrounding noise level on a street is measured to be 90 dB but the noise level inside a personal car is only 70 dB. What percentage of sound intensity outside the car is equal to the sound intensity inside the car?

- a) 77%
- b) 70%
- c) 20%
- d) 1%
- e)  $700/9\%$
- f) None of the above

5. A net force of 10 newtons accelerates an object at 5.0 meters per second<sup>2</sup>. What net force would be required to accelerate the same object at 1.0 meter per second<sup>2</sup>?

- a) 1.0 N
- b) 2.0 N
- c) 5.0 N
- d) 50 N
- e) 75 N
- f) 100 N

6. When a neutral metal sphere is charged by contact with a positively charged glass rod, the sphere \_\_\_\_\_.

- a) loses electrons
- b) gains electrons
- c) loses protons
- d) gains protons
- e) No 1 and 4 correct
- f) No 2 and 4 correct

7. An ideal gas is used to construct a constant pressure thermometer. It is noticed that when the temperature is 300 K, the volume recorded is 40 liters. As the temperature is lowered, it is seen that the volume decreases to 20 liters. What is the final temperature?
- a) 600 K    b) 300 K    c) 200 K  
d) 150 K    e) 100 K    f) 50 K
8. The latent heat of fusion of ice cream is 210 kJ/kg. How much heat is required to melt 0.5 kg of ice cream?
- a) 105 kJ    b) 420 kJ    c) 210.5 kJ  
d) 209.5 kJ    e) 210 kJ    f) None of these
9. Two identical metal plates have different temperatures; one is at 100°C and the other is at 60°C. They are placed in good thermal contact. What is their final temperature? Approximate same specific heats for both plates.
- a) 160°C    b) 40°C    c) 20°C  
d) 80°C    e) no change in temperatures    f) None of these
10. Consider a simple harmonic motion with an amplitude of  $A$ . Determine the displacement at the position where the velocity is half of the maximum velocity.
- a)  $\frac{1}{4}A$     b)  $\frac{1}{2}A$     c)  $\frac{3}{4}A$   
d)  $\frac{\sqrt{2}}{2}A$     e)  $\frac{\sqrt{3}}{2}A$     f)  $\frac{\sqrt{3}}{4}A$
11. A helicopter engine produces a pulling upward force that is 2 times its weight. Determine the maximum vertical acceleration of the helicopter. Use  $g = 10 \text{ m/s}^2$ .
- a)  $5 \text{ m/s}^2$     b)  $10 \text{ m/s}^2$     c)  $15 \text{ m/s}^2$   
d)  $20 \text{ m/s}^2$     e)  $25 \text{ m/s}^2$     f) None of these
12. A rock is thrown upward with a speed of 20 m/s. What maximum height in  $m$  does it reach before falling back to earth? (Use  $g = 10 \text{ m/s}^2$ )
- a) 20    b) 24    c) 28  
d) 26    e) 30    f) None of the above

13. What is the mass in kilograms of two liters of helium, where  $1.00 \ell = 1.00 \times 10^3 \text{ cm}^3$ ?

( $\rho_{\text{He}} = 0.179 \text{ kg / m}^3$ )

- a)  $3.58 \times 10^{-6}$
- b)  $3.58 \times 10^{-4}$
- c)  $3.58 \times 10^{-3}$
- d)  $8.65 \times 10^{-2}$
- e)  $8.65 \times 10^{-3}$
- f)  $8.65 \times 10^{-4}$

14. Which of the following resistance **cannot** be made by using the two 3-Ohm resistors and one 6-Ohm resistor?

- a) 5 Ohm
- b) 1.2 Ohm
- c) 7.5 Ohm
- d) 12 Ohm
- e) 9 Ohm
- f) 8 Ohm

15. A uniform rod AC of 8m long is bent to an L-shape at the point of 2m from one end.

The L-shaped rod is hanged freely at B. If 120 N weight is hanged at A and the equilibrium is reached then AB will make 60 degree with the vertical line as shown in the figure below. Find the weight of this rod.

- a) 114 N
- b) 172 N
- c) 229 N
- d) 286 N
- e) 300 N
- f) None of the above

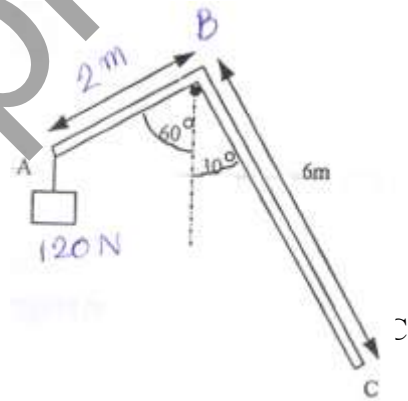

16. A small object is placed 10 cm from the centre of a gramophone disc and will move without skid when the disc is revolving. If the revolving speed is 45 rpm, then the coefficient of static friction between the object and the disc is \_\_\_\_\_.

- a) 0.04
- b) 0.22
- c) 0.44
- d) 0.56
- e) 0.6
- f) None of the above

17. Mass of the moon is  $\frac{1}{81}$  of the earth and its radius is  $\frac{1}{4}$  of the earth. If the acceleration due to gravity of the earth is  $10 \text{ m/s}^2$ , then the acceleration due to gravity of the moon is

- a) 1.67 m/s
- b) 1.98 m/s
- c) 2.50 m/s
- d) 3.33 m/s
- e) 4.5 m/s
- f) None of the above

18. Which type of the following electromagnetic waves suffers least diffraction on passing through a narrow slit?

- a) Gamma Rays
- b) Infrared rays
- c) Radio waves
- d) Violet light
- e) None of the above
- f) All are correct.

19. Which of the following circuit diagrams would be the best set up to find the power of the lamp?



20. A step-down transformer is shown in the figure below, the lamp grew dimly. The lamp would grow more brightly. If \_\_\_\_\_.

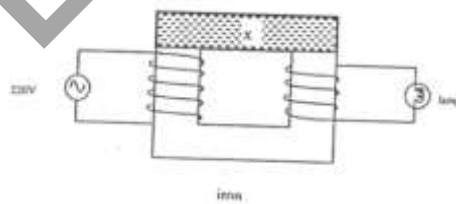

- a) The number of turns on the primary coil was reduced.
- b) The number of turns on the secondary coil was reduced.
- c) The iron was replaced by copper.
- d) The shaded section, x, were removed.
- e) None of the above
- f) All are correct.

21. Which of the following bodies has the largest kinetic energy?

- a) Mass  $M$  and speed  $4V$
- b) Mass  $2M$  and speed  $3V$
- c) Mass  $3M$  and speed  $2V$
- d) Mass  $3M$  and speed  $V$
- e) All have the same kinetic energy.
- f) None of the above

22. The accompanying figure 8 shows an array of resistors. The resistance of each resistor is  $R$ . What is the equivalent resistance of the network?

- a)  $3R/5$
- b)  $4R/5$
- c)  $2R$
- d)  $4R$
- e)  $8R$
- f) None of the above

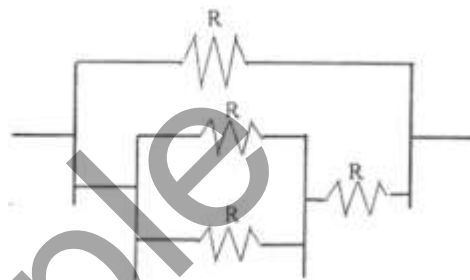

23. When a light passes through a narrow slit a resultant pattern of alternate bright and dark fringes occurs behind the slit. Which of the following statements best describe the situation?

- a) Light waves originating from all tiny segments of the wavefront are scattered by the slit and then interfere with each other.
- b) Light waves originating from all tiny segments of the wavefront are diffracted on passing through the slit and then interfere with each other.
- c) Light waves originating from all tiny segments of the wavefront spread out into the region behind the slit.
- d) Light waves originating from all tiny segments of the wavefront superimpose with each other and they are diffracted by the slit.
- e) All are correct.
- f) None of the above

24. A simple magnifying lens of has of focal length of 100 mm. If the virtual image is a 250 mm, what is the magnification of lens?

- a) 2.5X
- b) 3.0X
- c) 3.5X
- d) 4.0X
- e) 4.5X
- f) None of the above

25. What is the deBroglie wavelength for electron moving at a speed of  $7.25 \times 10^6$  m/s?

- a) 0.1 nm
- b) 1.0 nm
- c) 5.0 nm
- d) 10.0 nm
- e) 15.0 nm
- f) None of the above

26. A man pulls a 100-N crate up a frictionless  $30^\circ$  slope 5 m high as shown. Assuming that the crate moves at constant speed, the work done by the man is \_\_\_\_\_.

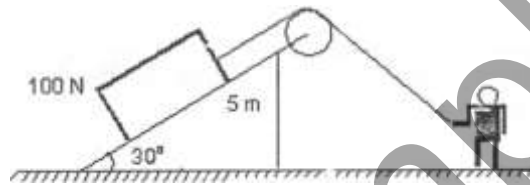

- a) -500 J
- b) -250 J
- c) 0
- d) 250 J
- e) 500 J
- f) 1000 J

27. A uniform 240-g meter stick can be balanced by a 240-g weight placed at the 100-cm mark, if the fulcrum is placed at the point marked \_\_\_\_\_.

- a) 75 cm
- b) 60 cm
- c) 50 cm
- d) 40 cm
- e) 80 cm
- f) 100 cm

28. A fluid is undergoing steady flow. Therefore, \_\_\_\_\_.

- a) the velocity of any given molecule of fluid does not change.
- b) the pressure does not vary from point to point.
- c) the velocity at any given point does not vary with time.
- d) the density does not vary from point to point.
- e) the flow is not uphill or downhill.
- f) None of the above

29. A charged capacitor and an inductor are connected in series. At time  $t = 0$  the current is zero, but the capacitor is charged. If  $T$  is the period of the resulting oscillations, the next time, after  $t = 0$  that the charge on the capacitor is a maximum is\_\_\_\_\_.

- a)  $T$
- b)  $T/4$
- c)  $T/2$
- d)  $T$
- e)  $2T$
- f)  $T/8$

30. The time required for a small pulse to travel from A to B on a stretched cord shown is NOT altered by changing\_\_\_\_\_.

- a) the linear mass density of the cord
- b) the length between A and B
- c) the shape of the pulse
- d) the tension in the cord
- e) none of the above (changes in all alter the time)
- f) All are correct.

Example